

Parking Brake and Actuation - Parking Brake

Description and Operation

COMPONENT LOCATION

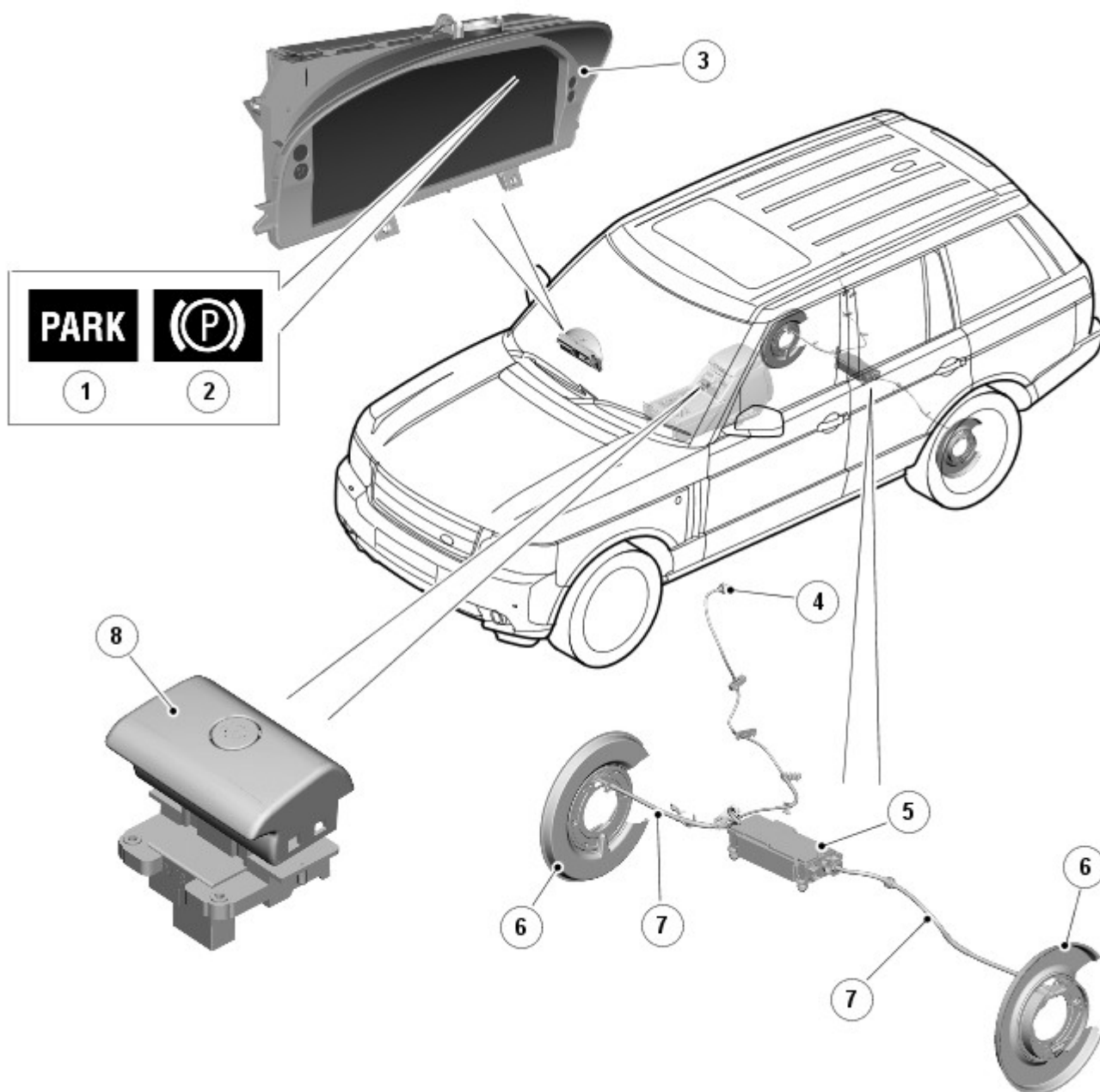

E131340

Item	Description
1	Parking brake indicator - USA market
2	Parking brake indicator - ROW markets
3	Instrument cluster
4	Emergency release cable
5	Parking brake module
6	Dust shield and parking brake shoes
7	Parking brake cable
8	Parking brake switch

OVERVIEW

The parking brake is an electrically actuated system that operates drum brakes integrated into the rear brake discs. The parking brake system consists of:

- A parking brake switch.
- Left and right drum brakes.
- Left and right brake cables.
- An emergency release cable.
- Two parking brake indicators.
- A parking brake module.

The parking brake is operated by the parking brake module, which adjusts the tension of the brake cables to apply and release the drum brakes. Operation of the parking brake module is initiated by the parking brake switch.

PARKING BRAKE SWITCH

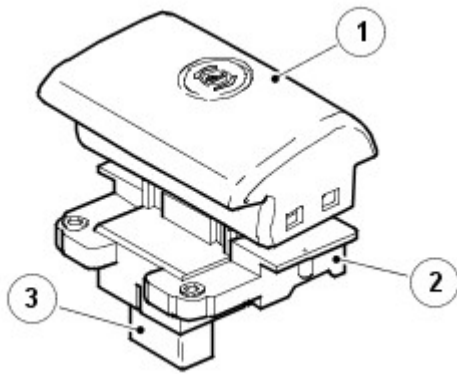

E77077

Item	Description
1	Operating handle
2	Switch body
3	Electrical connector

The parking brake switch is used by the driver to apply and release the parking brake, and is installed in the center console adjacent to the gear shift lever. An electrical connector on the back of the switch provides the interface with the vehicle wiring. A brake symbol on the switch illuminates when the exterior lamps are selected on.

There are 3 states for the parking brake switch:

- Apply request, when the handle of the parking brake switch is pulled up.
- Release request, when the handle of the parking brake switch is pushed down.
- Idle, when the handle of the parking brake switch is in the central or rest position.

Microswitches, incorporated into the parking brake switch, are activated by the handle of the parking brake switch. To determine the operating state of the parking brake switch, the parking brake module monitors the activity of the microswitches.

DRUM BRAKES



NOTE: right-hand (RH) brake shown, left-hand (LH) brake similar

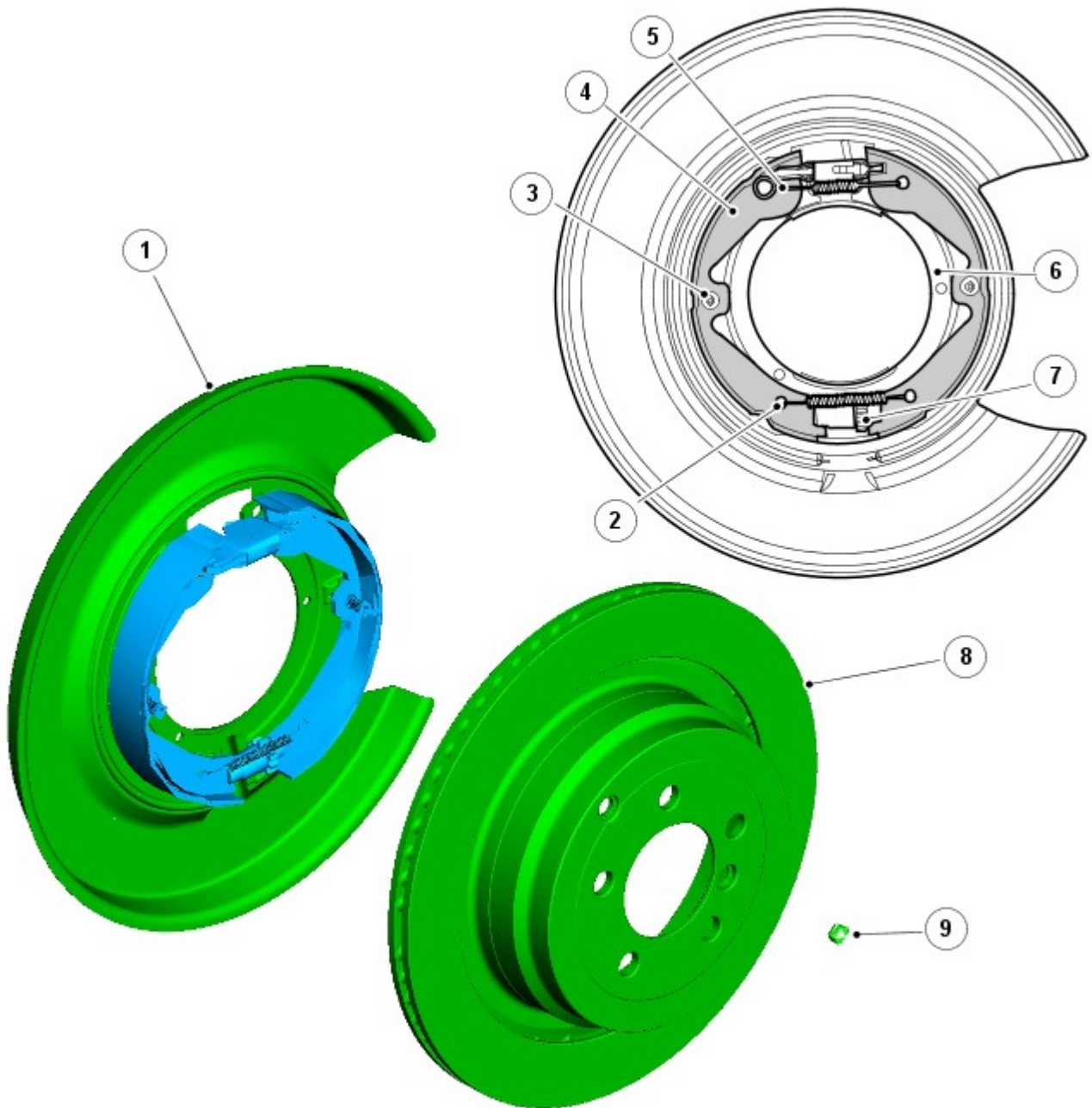

E81491

Item	Description
1	Dust shield
2	Adjuster spring
3	Shoe locating pin and clip
4	Brake shoe
5	Return spring
6	Backplate
7	Toothed wheel adjuster
8	Rear brake disc
9	Adjuster access plug

⚠ **WARNING:** The parking brake may not switch off until 20 minutes after the ignition is switched off. Automatic re-apply of the parking brake is possible and is not eliminated until this period has expired.

⚠ **CAUTION:** The parking brake module must be isolated from electrical power before attempting to remove a brake disc from the vehicle. Operation of the parking brake switch while a brake disc is removed may cause the actuating mechanism in the parking brake module to seize.

Each drum brake consists of a pair of brake shoes installed on a backplate attached to the rear hub carrier.

When the parking brake module tensions the brake cables, the movement is transmitted to an expander, which acts on both brake shoes. Brake shoe to drum clearance is set with a manual adjuster, which is accessed through a hole in the brake disc. The adjuster is a conventional toothed wheel adjuster.

After replacement of the brake shoes or brake discs, a bedding in procedure must be performed to ensure the drum brakes operate satisfactorily.

For additional information, refer to: [Parking Brake Shoes Bedding-In](#) (206-05 Parking Brake and Actuation, General Procedures).

BRAKE CABLES

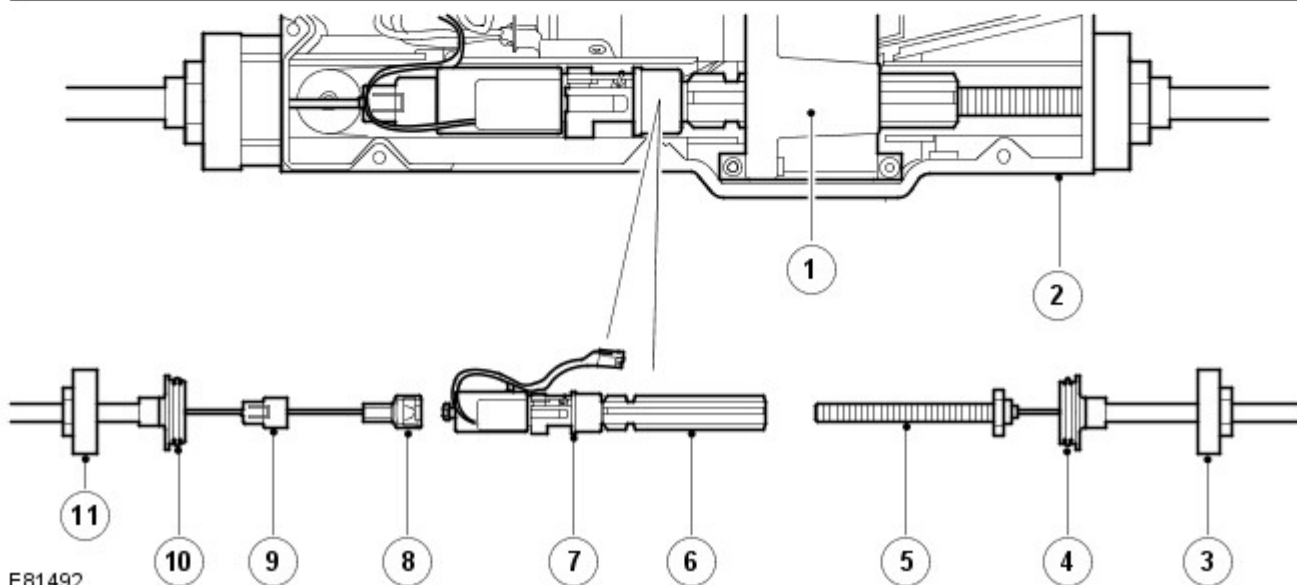
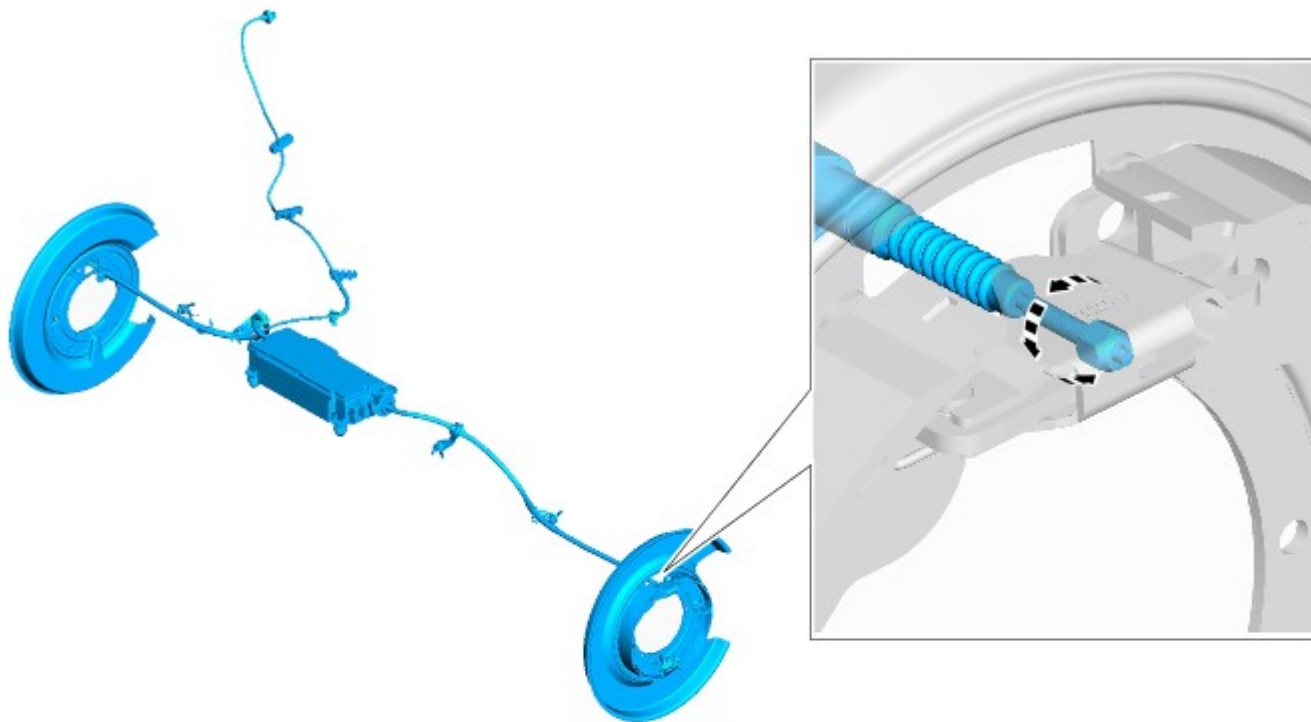

E81492

Item	Description
1	Gearbox
2	Parking brake module housing
3	Cable nut
4	Sealing collar
5	Threaded connector
6	Spline shaft
7	Force sensor
8	Shoe

9	Locking cover
10	Sealing collar
11	Cable nut



WARNING: The parking brake may not switch off until 20 minutes after the ignition is switched off. Automatic re-apply of the parking brake is possible and is not eliminated until this period has expired.



CAUTION: The parking brake module must be isolated from electrical power before attempting to remove a brake disc from the vehicle. Operation of the parking brake switch while a brake disc is removed may cause the actuating mechanism in the parking brake module to seize.

The brake cables consist of Bowden cables installed between the parking brake module and the drum brakes. The outer cable is attached to the respective wheel knuckle with a screw. The inner cable attaches to the expander and is secured in position with a nipple. In the parking brake module, the two inner cables are joined together via the force sensor and the spline shaft.

The inner cable of the RH brake cable is connected to a nipple on the force sensor by a 'shoe' on the end of the cable; a locking cover keeps the shoe engaged with the nipple.

The inner cable of the LH brake cable is connected to the spline shaft by a threaded connector (LH thread); a squared flange at the end of the threaded connector locates in the housing of the parking brake module, to prevent the threaded connector from turning with the spline shaft.

When the spline shaft turns, the threaded connector of the LH brake cable is screwed into or out of the spline shaft, which changes the effective length of the inner cables and operates the drum brakes. The ability of the spline shaft to move axially in the gearbox equalizes the load applied by the inner cables to the two drum brakes.

EMERGENCY RELEASE CABLE

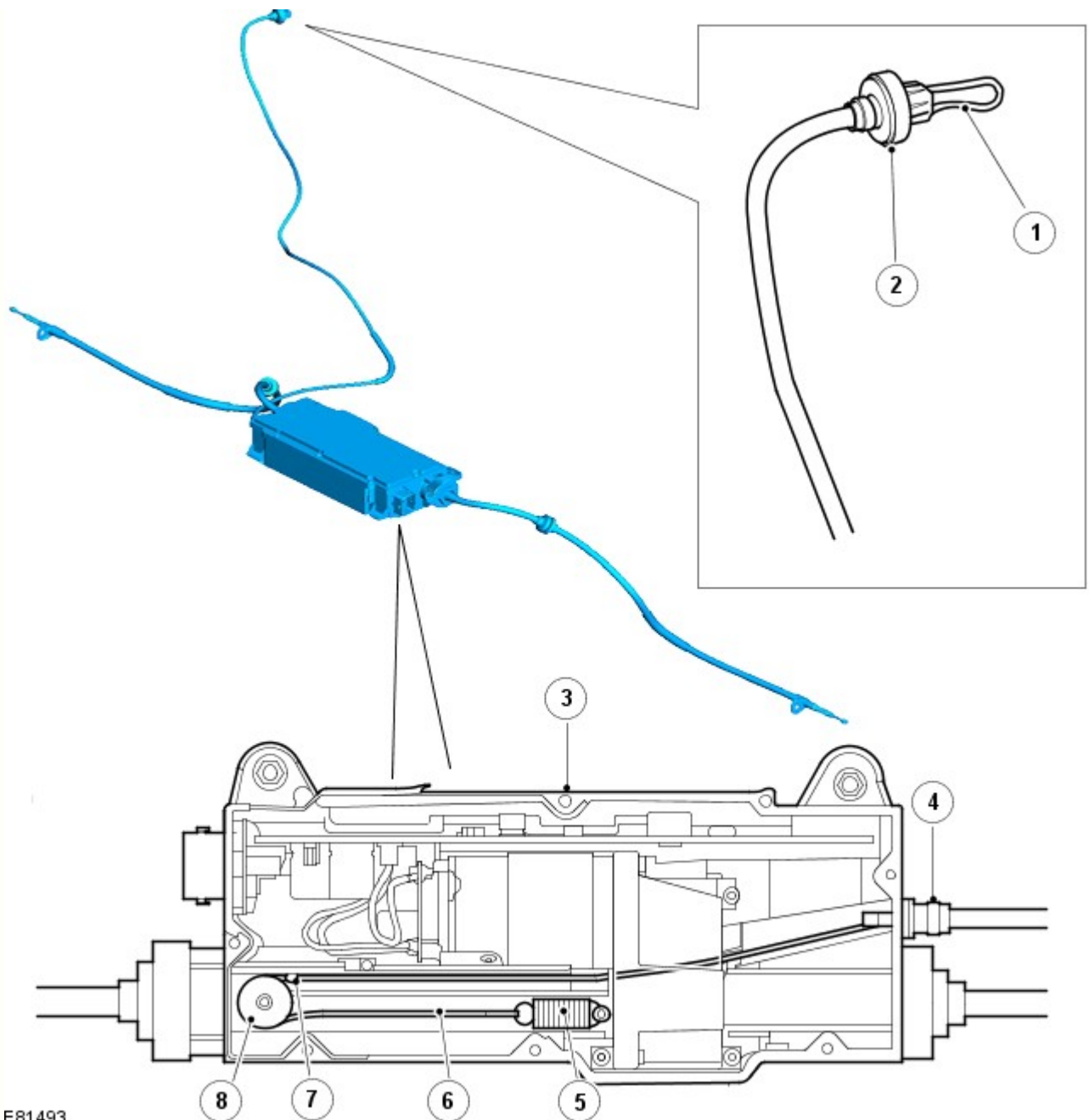

E81493

Item	Description
1	Pull ring
2	Quick release fitting
3	Parking brake module
4	Sealing collar
5	Spring
6	Inner cable
7	Nipple
8	Pulley wheel

The emergency release cable allows the parking brake to be mechanically released in the event that:

- The parking brake is not able to be electrically released due to a system fault.
- The battery is disconnected or battery voltage decreases below 7.5 volts while the parking brake is applied, preventing electrical release of the parking brake.

The parking brake is mechanically released by disconnecting the force sensor from the spline shaft in the parking brake module. During normal operation, the force sensor and the spline shaft are locked together by a lever operated pawl on the end of the spline shaft, which engages with a spigot on the force sensor.

The emergency release cable is a Bowden cable installed between the parking brake module and the luggage compartment. In the luggage compartment, a pull ring is installed on the end of the inner cable. The pull ring is designed to fit the hook on the end of the jack handle, and when used in combination with a screwdriver shaft, can be used to pull on the cable.

The pull required to release the latch is approximately 200 N (45 lbf). When the pull ring of the emergency release cable is released, the spring in the parking brake module retracts the inner cable and the nipple moves away from the pawl operating lever.

After the emergency release cable has been used to release the parking brake, the next time an apply selection is made with the parking brake switch, the parking brake module automatically runs through a latching procedure to reconnect the spline shaft with the force sensor. The parking brake module turns the spline shaft so that it moves towards the force sensor. The pawl of the spline shaft then re-engages with the spigot of the force sensor. A second apply selection with the parking brake switch is required to apply the parking brake.

PARKING BRAKE INDICATORS



E131341

Item	Description
1	Parking brake indicator - USA market
2	Parking brake indicator - ROW markets

The parking brake indicator illuminates red when the brake has been correctly applied.

If a fault is detected the warning lamp will flash red or illuminate yellow continuously and a 'PARKBRAKE' message will be displayed in the message center. For additional information, refer to:

Instrument Cluster (413-01, Description and Operation),
[Information and Message Center](#) (413-08 Information and Message Center, Description and Operation).



NOTE: The red brake warning indicator will continue to be illuminated for at least ten seconds after the ignition has been turned off.

PARKING BRAKE MODULE

The parking brake module monitors external and internal inputs and adjusts the tension of the brake cables to operate the drum brakes.

The parking brake module is installed directly on the rear subframe. Two rubber mounts, installed on lugs on the underside of the parking brake module, locate in holes in the subframe. The remaining corners of the parking brake module are secured to the subframe with shoulder bolts.

The main components of the parking brake module are:

- A PCB (printed circuit board) incorporating the ASIC (application specific integrated circuit) for control of the parking brake.
- An electric motor.
- A gearbox.
- A splined shaft.
- A force sensor.

The splined shaft and the force sensor are connected together by a latch on the end of the splined shaft. The splined shaft rotates on the latch and moves axially in the gearbox. The latch and the force sensor slide in a channel in the body of the parking brake module.

To apply or release the drum brakes, the parking brake module controls the operation of the electric motor to drive the gearbox. The gearbox rotates the splined shaft to increase or decrease the tension in the brake cables. The parking brake module monitors the load exerted by the brake cables using the input from the force sensor.

Interior of Parking Brake Module

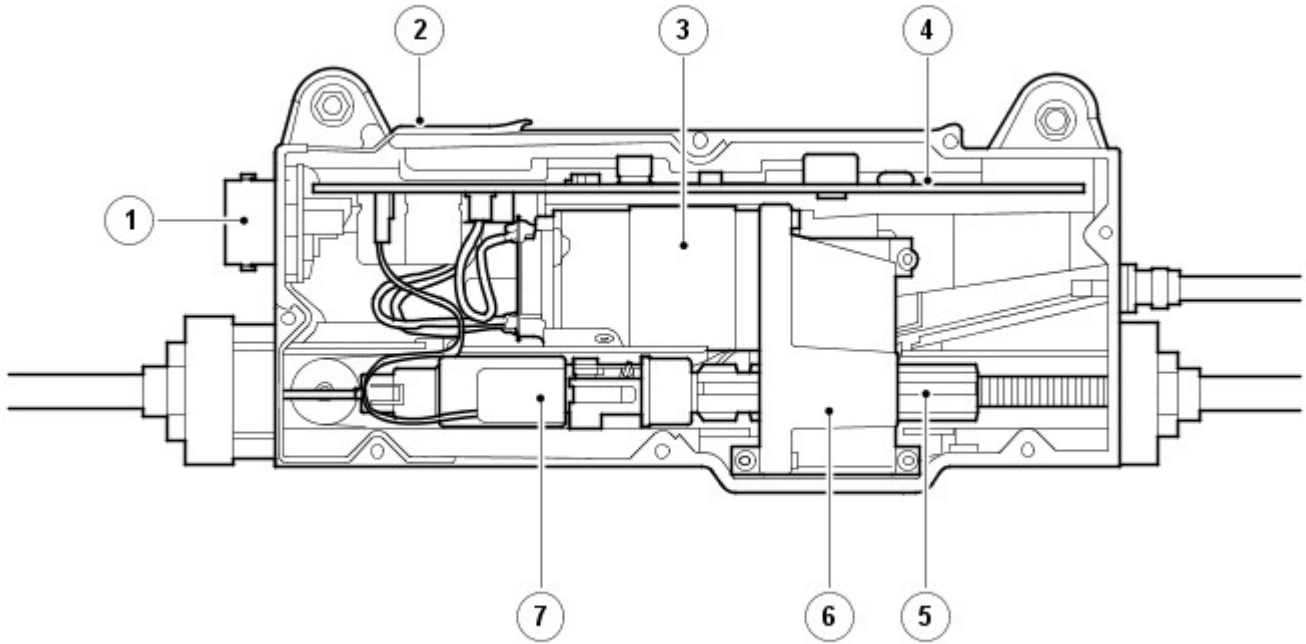

E81494

Item	Description
1	Electrical connector
2	Housing
3	Electric motor
4	PCB
5	Splined shaft
6	Gearbox
7	Force sensor

Inputs and Outputs

A 32 pin electrical connector on the RH side of the parking brake module provides the interface between the PCB and the vehicle wiring.

The parking brake module is powered by two permanent battery power feeds from the auxiliary junction box (AJB). A third connection with the central junction box (CJB) provides a battery voltage signal when the ignition switch is in position II (ignition). Other hardwired inputs include those from the parking brake switch.

In addition to the hardwired connections, the parking brake module is connected to the high speed controller area network (CAN) bus to enable communication with other vehicle systems.

CONTROL DIAGRAM



NOTE: **A** = Hardwired connection; **D** = High speed CAN bus; **N** = Medium speed CAN (controller area network) bus.

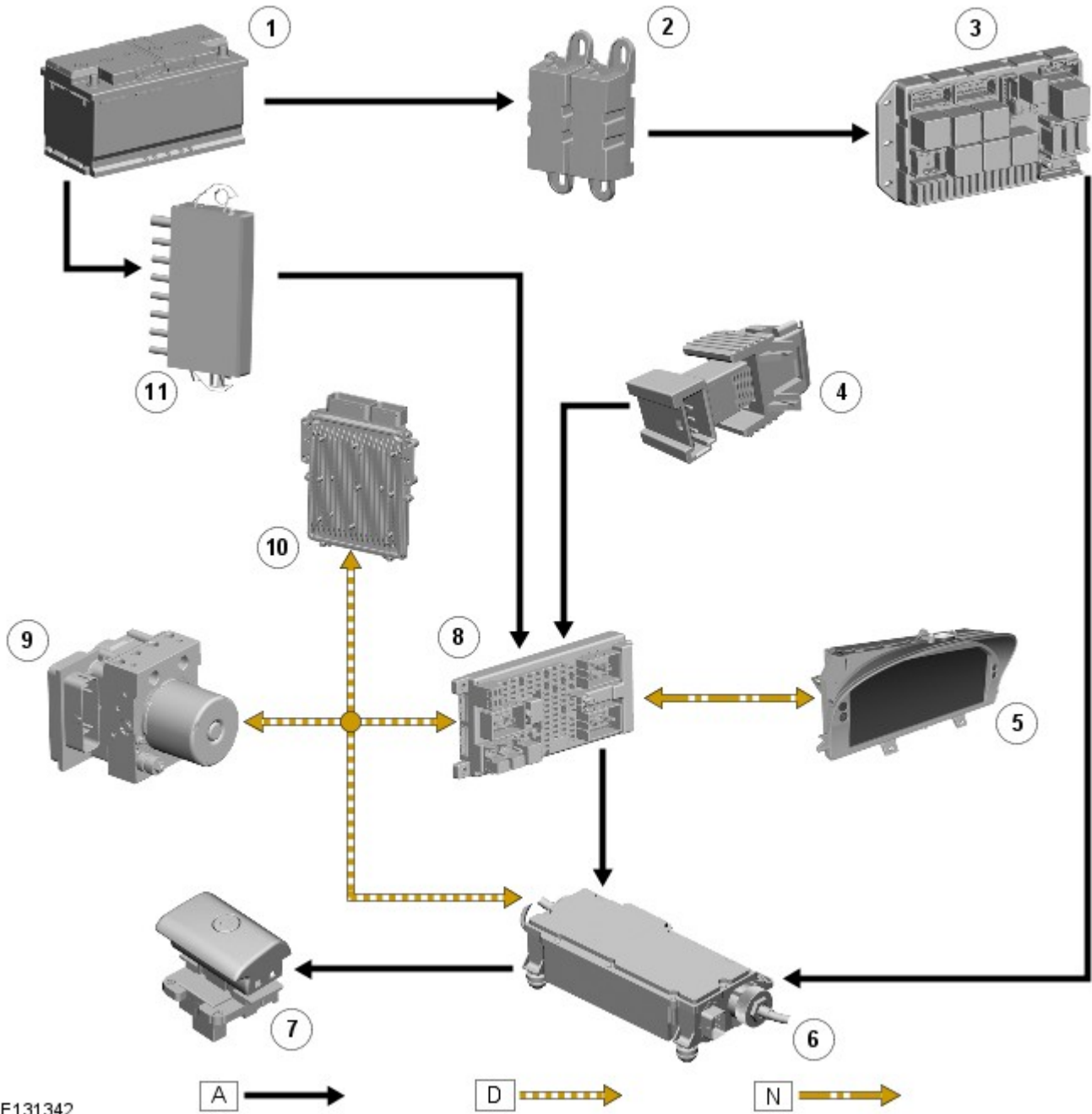

E131342

Item	Description
1	Battery
2	BJB (battery junction box) - 2
3	RJB (rear junction box)
4	Brake pedal switch
5	Instrument cluster
6	Parking brake module
7	Parking brake switch
8	CJB (central junction box)
9	anti-lock brake system (ABS) module
10	ECM (engine control module)
11	BJB

PRINCIPLES OF OPERATION

The parking brake can be applied at any time provided sufficient battery power is available. For the parking brake to be released, various pre-conditions are required. The parking brake has manual and automatic actuating modes, to cater for different operating circumstances, as detailed in the following table:

Actuating Modes

Mode	Pre-Conditions	Driver Action
Static apply	Vehicle speed less than 2.5 km/h (1.6 mph).	Pull up parking brake switch.
Static release	1. Vehicle speed less than 2.5 km/h (1.6 mph). 2. Engine running. OR Ignition switch in position II and brake pedal or accelerator pedal pressed.	Press down parking brake switch.
Dynamic apply	Vehicle speed more than 2.5 km/h (1.6 mph).	Pull up parking brake switch as required.
Dynamic release	Vehicle speed more than 2.5 km/h (1.6 mph).	Release (to neutral position) or press down parking brake switch.
DAR (drive away release)	1. Ignition switch in position II. 2. Transmission in gear 1, 2 or R (with high range selected) or 1, 2, 3 or R (with low range selected). 3. Accelerator pedal pressed more than 5%.	None. Parking brake released automatically on drive away.

Operating Voltages

Actuation of the parking brake (apply or release) is only started if the power supply to the parking brake module is within 9 to 18 volts. At any voltage in this range, the parking brake module is able to tighten the brake cables to the maximum, to fully apply the parking brake, although at voltages between 9 and 10.5 volts the actuation time may exceed 1.0 second.

During a parking brake actuation:

- If the power supply to the parking brake module decreases to less than 8.3 volts, the parking brake module continues the actuation, but stores a related diagnostic trouble code (DTC). If the ignition is on, the parking brake module also signals the instrument cluster to illuminate the amber parking brake warning indicator and flash the red parking brake warning indicator. On the instrument cluster, a message advising there is a parking brake fault is shown in the message center. The warning indications are discontinued if the power supply voltage increases to 8.3 volts or more.
- If the power supply voltage decreases to less than 7.5 volts, the parking brake module discontinues the actuation. Actuation is automatically resumed if the power supply voltage subsequently increases to 7.5 volts or more and the parking brake switch request is still valid.
- If the power supply voltage decreases below 6.5 volts, the parking brake function is disabled for the remainder of the ignition cycle.
- If the power supply voltage increases to more than 18.0 volts, the parking brake module immediately disables the parking brake function and stores a related DTC. If the ignition is on, the parking brake module also signals the instrument cluster to illuminate the amber parking brake warning indicator and flash the red parking brake warning indicator. On the instrument cluster, a message advising that the parking brake has a fault and is not functioning is shown in the message center. The parking brake function remains disabled until the power supply voltage is within 9 to 18 volts again. When the power supply voltage is within 9 to 18 volts again, the warning indications are cancelled and actuation is automatically resumed if the parking brake module is in a dynamic mode of operation with a valid parking brake switch request.



NOTE: The instrument cluster shuts down below 8 volts, so warning indications and messages are not displayed below 8 volts. CAN transmission stops if battery voltage drops below 7.0 volts and re-starts when voltage goes above 7.5 volts.

Sleep Mode

To reduce quiescent drain on the vehicle battery, the parking brake module incorporates a sleep mode. The parking brake module enters the sleep mode, provided the ignition is off and there are no signals from the wheel speed sensors, when one of the following occurs:

- 20 minutes elapse after the last actuation of the parking brake.
- If no actuation occurred, 20 minutes elapse after the ignition is switched off.

The parking brake module wakes up from the sleep mode when one of the following occurs:

- An apply or release request is made with the parking brake switch.
- The ignition is turned on.

The parking brake module wakes up within 500 ms. The high speed CAN bus is activated within 200 ms maximum.

When the parking brake module is woken with a release request from the parking brake switch, the parking brake module ignores the request but illuminates the red brake warning indicator. The parking brake module extinguishes the red brake warning indicator and goes back to sleep immediately the switch is released to the neutral position.

When the parking brake module is woken with an apply request from the parking brake switch, if the parking brake is already applied the parking brake module ignores the request but illuminates the red brake warning indicator. The parking brake module extinguishes the red brake warning indicator and goes back to sleep immediately the switch is released to the neutral position. If the parking brake is in the released condition when the apply request is made, the parking brake module illuminates the red brake warning indicator and applies the parking brake. The parking brake module extinguishes the red brake warning indicator and goes back to sleep 3 minutes after the apply activation, or immediately after the switch is released to the neutral position, whichever occurs first.

Dynamic Apply

In the dynamic apply mode, if the vehicle speed is more than 10 km/h (6.25 mph) when the parking brake switch is selected to apply, the parking brake module requests the ABS module to activate the disc brakes on all four wheels. When the vehicle comes to a standstill, the parking brake module statically applies the parking brake. Once the static load is achieved, the hydraulic pressure is removed. If the parking brake switch is released to the neutral position, or pressed down to the release position, during dynamic apply, braking is cancelled.

The ABS module monitors the deceleration rate using the wheel speed sensor signals, and adjusts the hydraulic pressure to the disc brakes as required to achieve the required rate. All of the anti-lock control - traction control system brake functions remain enabled in the dynamic apply mode.

The parking brake module incorporates two fallback functions for the dynamic apply mode:

- Fallback 1 is invoked if vehicle speed is between 2.5 km/h (1.25 mph) and V_{max} when the parking brake switch is selected to apply and the ABS module is unable to fulfil a hydraulic request. When fallback 1 is invoked, the parking brake module decelerates the vehicle using only the parking brake. The parking brake module monitors the deceleration rate using the wheel speed information from the ABS module, and adjusts the tension of the brake cables to achieve the required rate. During deceleration the parking brake module also uses the wheel speed inputs from the ABS module to operate an anti-lock function for the rear wheels. When vehicle speed decreases to 2.5 km/h (1.25 mph) the parking brake module changes to the static apply mode.
- Fallback 2 is invoked if the ABS module fails. In this instance the parking brake module monitors the output shaft speed sensor on the transmission to determine if a static or dynamic condition exists.
- Fallback 3 is invoked if there is a loss of communication between the parking brake module and the CAN bus has failed. When fallback 3 is invoked, the parking brake module decelerates the vehicle using only the parking brake. The parking brake module tightens the brake cables under the control of the driver, no anti-lock function is available.

While dynamic apply is active, including fallback 1, 2 and fallback 3, the parking brake module also outputs high speed CAN bus signals to:

- The ABS module, to apply the stop lamps.
- The instrument cluster, to sound an intermittent warning buzzer, at 0.5 second on, 1.0 second off.
- The instrument cluster, to illuminate the red parking brake warning indicator. The indicator is permanently illuminated except in fallback 3, when it flashes.

DAR Pre-arming

The DAR pre-arming function operates when the transfer box is in high range to reduce the parking brake release time during DAR and to provide a smooth take-off. DAR pre-arming is invoked when:

- The ignition switch is in position II.
- The transmission is in gear 1, 2 or R.
- The vehicle is stationary.
- No failsafe tighten actuation has occurred.

Automatic Load Adjustment

While the ignition is on, the parking brake module constantly monitors the input from the force sensor. If the tension of the brake cables goes outside the limits for a given operating mode, the parking brake module automatically restores the tension within limits.

Failsafe Tighten. If, during DAR pre-arming, the vehicle moves, then the maximum cable force is reinstated for the remainder of that ignition cycle.

Automatic Apply. While the parking brake is applied, if the tension of the brake cables decreases by a prescribed amount from the initial setting, the parking brake module automatically restores the tension to the initial setting.

Automatic Release. While the parking brake is released, if the tension of the brake cables increase to a prescribed amount, the parking brake module automatically reduces the tension to zero.

Parking Brake Switch Monitoring

The parking brake module monitors for the following types of fault in the parking brake switch system:

- Short circuits between a pull-down transistor in the parking brake module and battery voltage.
- Broken wires and microswitches.
- Plausibility.

If a fault is detected, the parking brake module stores a related fault code.

The parking brake switch has a degree of in-built redundancy. If a single microswitch fault is detected the parking brake module can still determine the operating state of the parking brake switch. Short circuits or multiple failures cause the parking brake module to disable the parking brake switch for the remainder of the ignition cycle. The parking brake module also disables the parking brake switch if a plausibility fault occurs. However, since plausibility faults are usually caused by incomplete operation of the parking brake switch, the parking brake switch is re-enabled if the parking brake module subsequently establishes a plausible operating state.

If a single microswitch fault is detected, the parking brake module signals the instrument cluster to illuminate the amber parking brake warning indicator. The parking brake module also signals the instrument cluster to display a message advising there is a parking brake fault. During an apply actuation, the parking brake module also signals the instrument cluster to flash the red parking brake warning indicator.

For all other fault types, the parking brake module signals the instrument cluster to illuminate the amber parking brake warning indicator and to display a message advising the parking brake has a fault and is not functioning. If it makes an apply actuation, the parking brake module signals the instrument cluster to flash the red parking brake warning indicator for the remainder of the ignition cycle.

On the next ignition cycle, the warning indicators and the messages are only activated if the fault is still present, although the DTC is retained by the parking brake module until cleared by the Land Rover approved diagnostic system.